

BTM003

Bluetooth Module Specification

Ver1.1

1. PRODUCT DESCRIPTION AND SPECIFICATION



Top View

1.1 Product Description

This product is a Class 2 SMT Bluetooth Module used CSR BC3-MultiMedia External. It provides data and voice communications. It interface with a host through USB or UART and support data rate up to 723.2K/57.6Kbps.

1.2 General Features

- . • **Class 2 Bluetooth Module**
- . • **Bluetooth v1.2 Specification Compliant**
- . • **Full Piconet Support**
- . • **Scatternet Support**
- . • **Full Bluetooth data rate, up to 723kb/s asymmetric**
- . • **Built in 16-bit Stereo Codec**
- . • **Digital Audio Interface : PCM, I2S, SPDIF**
- . • **Flash Memory can be factory configured to either 4MB,**

8MB (8MB can either configure as single bank or separated into two banks with 4MB each and control by external bank switching pin) or **16MB** (16MB is separated into two banks with 8MB each and control by external bank switching pin)

- Factory configurable to either 1.8V or 3.3V supply.

1.3 Specifications

Operating Frequency Band	2.4GHz ~ 2.48GHz unlicensed ISM band
Bluetooth Specification	V1.2
Output Power Class	Class 2
Operating Voltage	1.8V / 3.3V
Host Interface	USB 1.1 or UART
Audio Interface	PCM, I2S, SPDIF
Flash Memory Size	4M, 8M (with and without bank switching), 16MBit (With bank switching)
Dimension	25mm (L) x 12.5 (W) mm x 2.35mm (H)

Specifications are subject to change without prior notice

Electrical Characteristics

Absolute Maximum Rating	Min	MAX
Storage Temperature	-40°C	+85°C
Supply Voltage, (VDD, VPA)	-0.30V	+3.60V

Recommended Operating Conditions	Min	Max
Operating Temperature Range	-25°C	+75°C
Supply Voltage, (VCC)	3.0V	3.6V
Supply Voltage, (VDD)	1.7V	1.9V

Power Consumption	Units	Average
SCO Connection HV3 (30ms interval sniff mode)	.mA	21
SCO Connection HV1	mA	42
ACL Data Transfer 115.2Kbps UART no traffic(Master)	mA	5
ACL Data Transfer 115.2Kbps UART no	mA	22

traffic(Slave)		
ACL Data Transfer 721Kbps USB	mA	45
Standby	mA	0.15
CODEC		
Microphone inputs and ADC/channel	mA	0.85
DAC and loudspeaker driver, no signal/channel	mA	1.4
Digital audio processing subsystem	mA	8

VDD = 3.3V; f = 2.45GHz; T=20 ° C

RF Characteristics

Receiver	Units	Min	Typ	Max	Bluetooth Spec
Sensitivity at 0.1% BER	dBm	-	-80	-78	-70
Maximum Receiver Signal	dBm	-	-	-8	-20
C/I Co-Channel	dB	-	9	-	11
Adjacent Channel Selectivity C/I 1MHz	dB	-	-	0	0
2nd Adjacent Channel Selectivity C/I 2MHz	dB	-	-	-30	-30
3rd Adjacent Channel Selectivity C/I >3MHz	dB	-	-	-40	-40
Image Rejection C/I	dB	-	-	-9	-9

VDD = 3.3V; f = 2.45GHz; T=20 ° C

Transmitter	Units	Min	Type	Max	Bluetooth Spec
RF Output Power	dBm	-	3	-	-6 to +4
RF Power Control Range	dB	-	30	-	> 16
RF Power Range Control Resolution	dB	2	-	6	-
20dB Bandwidth for Modulated Carrier	KHz	-	850	-	<1000
2nd Adjacent Channel Power (+/-	dBc	-	-	-	-20

2MHz)					
3rd Adjacent Channel Power (+/- 3MHz)	dBc	-	-	-	-40

VDD = 3.3V; f = 2.45GHz; T=20 ° C

All specifications including pinouts and electrical specifications may be changed without prior notice

2. HARDWARE DESCRIPTION

2.1 Block Diagram

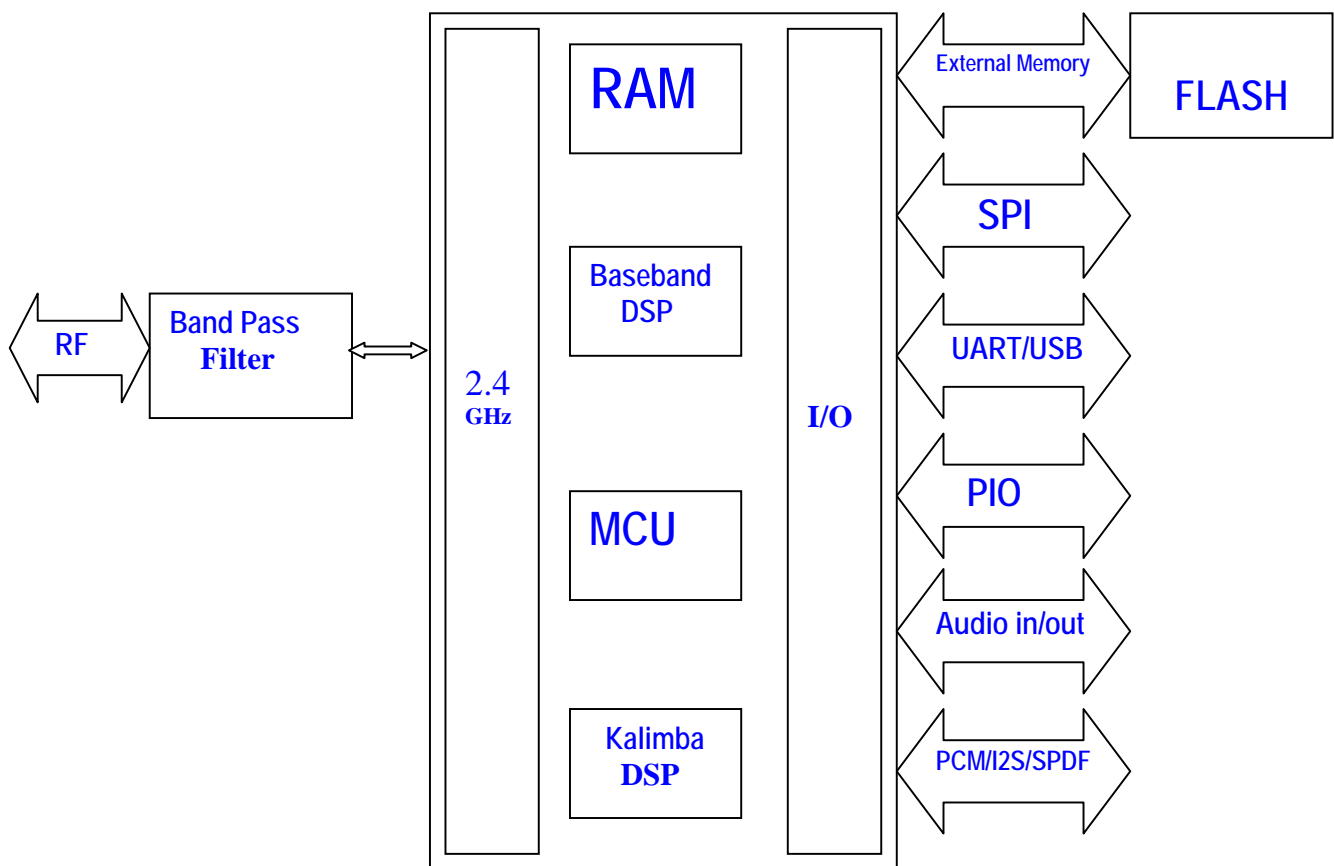
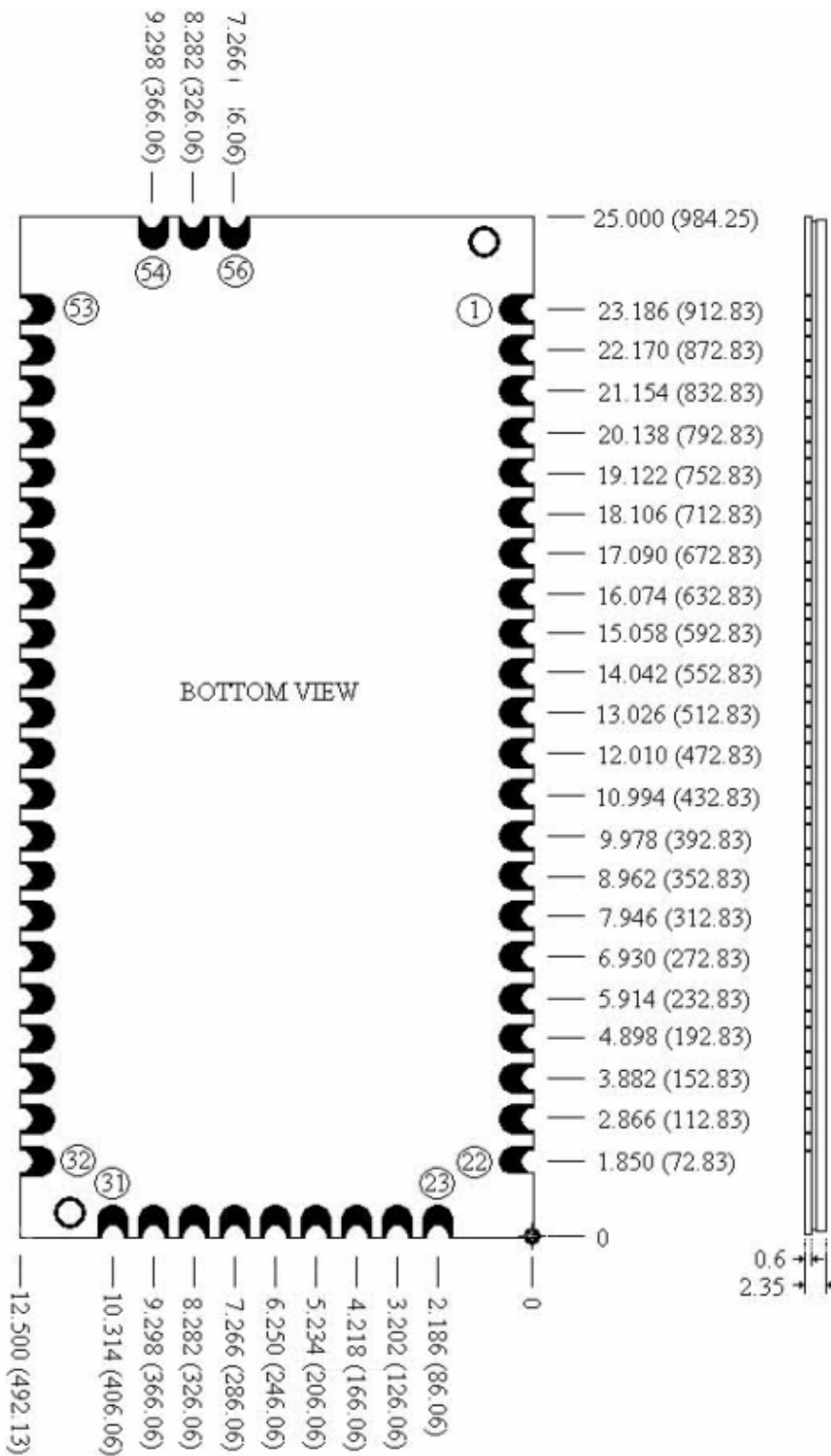

Figure 1 : Block Diagram

2.2 Pin Configuration and Mechanical Dimension



2.3 Pin Description

PIN NO.	NAME	TYPE	FUNCTION	RE-MARK
1	EXT_CLK	Analogue	External Clock Inout	For external clock input. (Refer to Section 2.4.2)
	N.C.			For Built In Crystal
2	GND	GND	Ground	
3	VDD	POWER	+1.8V Supply	For 1.8V Version
	N.C.			For 3.3V Version
4	GND	GND	Ground	
5	AUDIO_OUT_P_LT	Analogue	Audio Line Out Positive (Left Side)	
6	AUDIO_OUT_N_LT	Analogue	Audio Line Out Negative (Left Side)	
7	AUDIO_OUT_N_RT	Analogue	Audio Line Out Negative (Right Side)	
8	AUDIO_OUT_P_RT	Analogue	Audio Line Out Positive (Right Side)	
9	VCC	POWER	+3.3V Supply	For 3.3V Version
	VDD	POWER	+1.8V Supply	For 1.8V Version
10	GND	GND	Ground	
11	AUDIO_IN_P_LT	Analogue	Audio Line In Positive (Left Side)	
12	AUDIO_IN_N_LT	Analogue	Audio Line In Negative (Left Side)	
13	AUDIO_IN_N_RT	Analogue	Audio Line In Negative (Right Side)	
14	AUDIO_IN_P_RT	Analogue	Audio Line In Positive (Right Side)	
15	GND	GND	Ground	
16	B_SW	CMOS Input	Bank Switching Selection	
17	AIO0	Bi-directional	Programmable input/output line	
18	AIO1	Bi-directional	Programmable input/output line	

19	AIO3	Bi-directional	Programmable input/output line	
20	GND	GND	Ground	
21	USB_DP	Bi-directional	USB Data Plus	
22	USB_DN	Bi-directional	USB Data Minus	
23	UART_RTS	CMOS Output	UART Request To Send (Active Low)	
24	UART_CTS	CMOS Input	UART Clear To Send (Active Low)	
25	UART_RX	CMOS Input	UART Data Input (Active High)	
26	UART_TX	CMOS Output	UART Data Output (Active High)	
27	GND	GND	Ground	
28	PCM_IN	CMOS Input	Synchronous Data Input	
29	PCM_SYNC	Bi-directional	Synchronous Data Sync	
30	PCM_CLK	Bi-directional	Synchronous Data Clock	
31	PCM_OUT	CMOS Output	Synchronous Data Output	
32	PIO7	Bi-directional	Programmable Input/Output Line	
33	PIO6	Bi-directional	Programmable Input/Output line	
34	PIO5	Bi-directional	Programmable Input/Output line	
35	PIO4	Bi-directional	Programmable Input / Output Line	
36	GND	GND	Ground	
37	SPI_CSB	CMOS Input	Chip Select For Synchronous Serial Interface (Active Low)	
38	SPI_CLK	CMOS Input	Serial Peripheral Interface Clock	
39	SPI_MOSI	CMOS Input	Serial Peripheral Interface Data Input	
40	SPI_MISO	CMOS Output	Serial Peripheral Interface Data Output	

41	GND	GND	Ground	
42	RESET_B	CMOS Input	Reset if Low	
43	RESET	CMOS Input	Reset If High	
44	GND	GND	Ground	
45	PIO3	Bi-directional	Programmable Input/Output Line	
46	PIO2	Bi-directional	Programmable Input / Output Line	
47	PIO1	Bi-directional	Programmable Input / Output Line	
48	PIO0	Bi-directional	Programmable Input / Output Line	
49	GND	GND	Ground	
50	PIO11	Bi-directional	Programmable Input/Output Line	
51	PIO10	Bi-directional	Programmable Input/Output Line	
52	PIO9	Bi-directional	Programmable Input/Output Line	
53	PIO8	Bi-directional	Programmable Input/Output Line	
54	GND	GND	Ground	
55	RF-IN	RF	RF Interface	
56	GND	GND	Ground	

2.4 Configuration

2.4.1 Operating Voltage Selection

This module can be factory configured to either operating at 1.8V or 3.3V.

	VCC	VDD
1.8V Version	1.8V	1.8V
3.3V Version	3.3V	NC

2.4.2 Clock Input Selection

The clock for this module can be driven either from a build in crystal or from external source.

	Internal Crystal	External Clock
R1	Do Not Installed	0 ohm Resistor
Y1	Installed	Do Not Installed
C11	3.3pF Capacitor	Do Not Installed
C12	10pF Capacitor	0 ohm Resistor

For detail description of external clock selection, refer to reference 1.

3 Bank Switching Selection

Different flash memory size and configuration can be factory selected depend on the application.

Bank Switching	Flash Size	R3	R5	R9
No	4MB	0	0	0
No	8MB	0	0	1
Yes	8MB	1	0	0
Yes	16MB	0	1	1

0: Do Not Install

1 : Install

Bank Switching	Flash Size	R3	R5	R9
No	4MB	0	0	0
No	8MB	0	0	1
Yes	8MB	1	0	0
Yes	16MB	0	1	1

0: Do Not Install

1 : Install